

INSTRUCTION MANUAL

REGULATED DC POWER SUPPLY

MODEL PAD600-1

KIKUSUI ELECTRONICS CORPORATION

78.12.11

783659

Power Requirements of this Product

Power requirements of this product have been changed and the relevant sections of the Operation Manual should be revised accordingly.

(Revision should be applied to items indicated by a check mark)

Input voltage

The input voltage of this product is _____ VAC,
and the voltage range is _____ to _____ VAC. Use the product within this range only.

Input fuse

The rating of this product's input fuse is _____ A, _____ VAC, and _____.

WARNING

- To avoid electrical shock, always disconnect the AC power cable or turn off the switch on the switchboard before attempting to check or replace the fuse.
- Use a fuse element having a shape, rating, and characteristics suitable for this product. The use of a fuse with a different rating or one that short circuits the fuse holder may result in fire, electric shock, or irreparable damage.

AC power cable

The product is provided with AC power cables described below. If the cable has no power plug, attach a power plug or crimp-style terminals to the cable in accordance with the wire colors specified in the drawing.

WARNING

- The attachment of a power plug or crimp-style terminals must be carried out by qualified personnel.

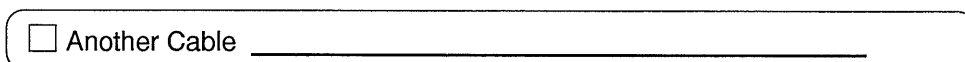
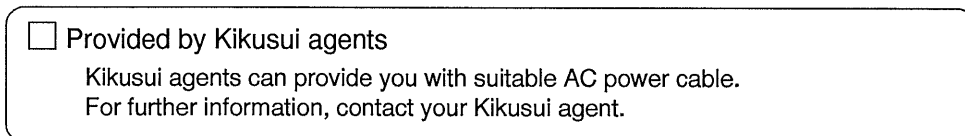
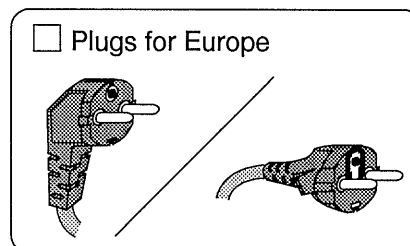
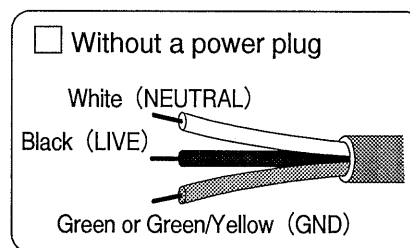

PRECAUTIONS

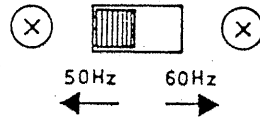

Before operating this instrument, ensure that the 50Hz/60Hz selector switch on the rear panel is set in the position corresponding to the frequency of the AC line on which the instrument is to be operated. Note that the operation may be unstable if the switch is not set correctly. Avoid tampering of the switch.

This instrument is incorporated with a protection circuit against shorted output. This circuit instantaneously reduces the output current in order to protect the control transistors when the output terminals are short-circuited by mistake or when the output voltage has become dangerously high (higher than approximately V).

TABLE OF CONTENTS

	<u>PAGE</u>
1. GENERAL	1
2. SPECIFICATIONS	3
3. OPERATION METHOD	7
3.1 Explanation of Front and Rear panels	7
3.2 Notes in Use	10
3.3 How to Use the Sampling Terminals	12
3.4 Constant-voltage Constant-current Characteristics..	14
3.5 Transiential Response	15
3.6 Single-unit Operation	18
3.7 Parallel Operation	20
3.8 One-control Operation (Master/Slave Operation)	22
3.9 Remote Control Operation	24
4. CIRCUIT DESCRIPTION	28
4.1 Constant-voltage Circuit	28
4.2 Constant-current Circuit	29
* Block diagram	
* Current consumption characteristic curves	

783860

1. GENERAL

Kikusui Model PAD 600-1 General-purpose Constant-voltage Constant-current Power Supply employs high performance monolithic IC's and silicon transistor and it provides high operation reliability and excellent electrical performance. The PAD600-1 is most rationally designed with full attention to the matters related to high voltage supply.

The PAD 600-1 has a pre-stabilization circuit which employs SCRs, thereby sufficiently reducing heat generation and realizing a compact power supply without requiring forced air cooling.

The PAD 600-1 incorporate novel circuits, attaining a lower temperature coefficient ($50 \text{ PPM}/^{\circ}\text{C}$) a faster response speed $50 \mu\text{sec}$ (5 ~ 100%) and a lower drift as compared with conventional types of high voltage power supplies.

The PAD 600-1 is designed with full safety features (inculation of capacitors, insulation of printed board connectors, double-insulation of heat sink, etc.) for high voltage supply. It also incorporates a short protection circuit, a temperature protection circuit with thermal sensor, and an overvoltage protection circuit which is brought into effect when the output voltage has become uncontrollably high. With these features the PAD 600-1 operates with the highest safety and reliability, and possible adverse effects on the load equipment are reduced to the practicable minimum.

783861

The output voltage is controllable for a range of 0 ~ 600 V, finely with a 10-turn potentiometer. The constant-current setting is variable for a range of 50 mA ~ 1 A.

When a larger current is required, two or more units of PAD 600-1 can be operated in a regular parallel operation or in a one-control parallel operation. Remote control operation with an external resistor also is possible. (See Para. 3.9.)

The PAD 600-1 , which is a high voltage type, cannot be used being two or more units connected in series operation.

783862

2. SPECIFICATIONS

Power requirements: 100 V $\pm 10\%$, 50/60 Hz single-phase AC,
approx. 1.5 kVA (full load)

Dimensions: 430 W \times 160 H \times 400 D mm

(Maximum dimensions): 431 W \times 175 H \times 490 D mm

Weight: Approx. 27 kg

Ambient temperature: 0 ~ 40°C

Accessories:

Shorting bar (long)	1
Input power fuses (30 A)	2
Input power cord (approx. 3 m)	1
Instruction manual	1

Terminals: "-", GND, "+" (horizontal layout).
On both front and rear panels terminals.

Output polarity: Positive or negative

Voltage to ground: ± 600 V maximum

Cooling system: Unforced air cooling (natural convection)

Constant-voltage characteristics

Voltage: 0 ~ 600 V, continuously variable with
10-turn potentiometer

Current: 1 A maximum

Ripple noise (5 Hz ~ 1 MHz): 1 mV rms

Output voltage regulation

Input change: 0.005% + 1 mV change of output voltage by
 $\pm 10\%$ change of input voltage (nominal 100 V)

Load change: 0.005% + 2 mV change of output voltage by
0 ~ 100% change of output current.

(When sampling terminal is used)

Transient response characteristics (5 ~ 100%): 50 μ sec (typical)

Temperature coefficient: 50 PPM/ $^{\circ}$ C (typical)

Constant-current characteristics

Voltage: 0 ~ 600 V, continuously variable with
10-turn potentiometer

Current: 50 mA ~ 1 A , continuously variable with
1-turn variable resistor

783864

Ripple noise: 1 mA rms (5 Hz ~ 1 MHz)

Output current regulation

Input change: 1 mA by $\pm 10\%$ change of input voltage
(nominal 100 V)

Load change: 2 mA by 1 V ~ 600 V change of output voltage

Operation modes: Regular parallel operation
One-control parallel operation
Output-voltage remote control operation

Constant-voltage, constant-current operation indication:

With LED lights	Constant-voltage	green
	Constant-current	red

Internal temperature detection circuit:

Cuts out the output power (the input circuit breaker trips) when transistor heat sink temperature has become 105°C .

Voltmeter: DC 640 V, JIS Class 2.5

Ammeter: DC 1.2 A, JIS Class 2.5

Options:

Rack mount angles (for mounting on 19-inch
or 500-mm standard rack)

Overvoltage, overcurrent protection unit
(option)

783866

3. OPERATION METHOD

3.1 Explanation of Front and Rear Panels

(See Figures 3-1 and 3-2.)

① POWER switch:

Main power switch of the instrument. The upper position is for power ON. This switch is automatically cut out when temperature detection circuit has tripped or output voltage has become uncontrollable.

② POWER lamp:

Indicates the ON/OFF state of main power. The lamp turns on when the power is on.

③ QV (constant voltage) lamp:

This green LED lamp turns on when instrument is operating in constant-voltage mode.

④ C.C (constant current) lamp:

This red LED lamp turns on when instrument is operating in constant-current mode.

⑤ VOLTAGE SET knob:

For setting the output voltage. The voltage increases as this knob is turned clockwise.

⑥ CURRENT SET knob:

For setting the output current. The current increases as this knob is turned clockwise.

⑦ Voltmeter:

Indicates the output voltage. DC 640 V, JIS Class 2.5

⑧ Ammeter:

Indicates the output current. DC 1.2 A, JIS Class 2.5

⑨ Output terminals:

Delivers the output power. Layout is "-" (black), GND (black) and "+" (black) from left to right.

⑩ Rear terminal board:

Has terminals for output, sampling, GND, remote control, and one-control para.

- ⑪ 50Hz/60Hz selector switch:

Selects the AC line frequency. Set this switch in the position corresponding to the AC line frequency of your area.

- ⑫ AC INPUT terminals:

AC input power terminals for AC, AC, GND lines. Connect the AC power cord (accessories supplied) to these terminals.

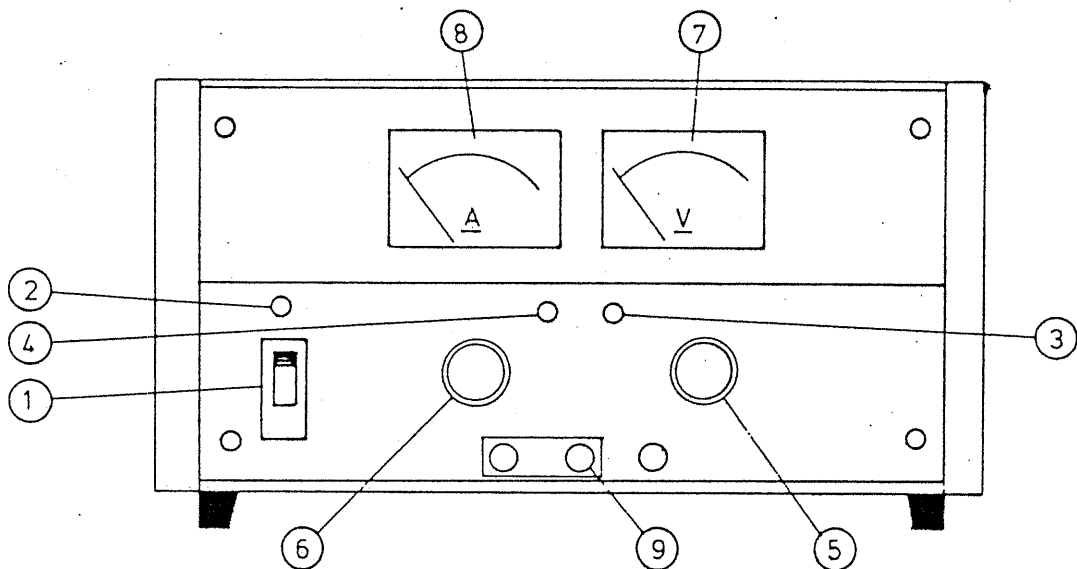

Figure 3-1

783869

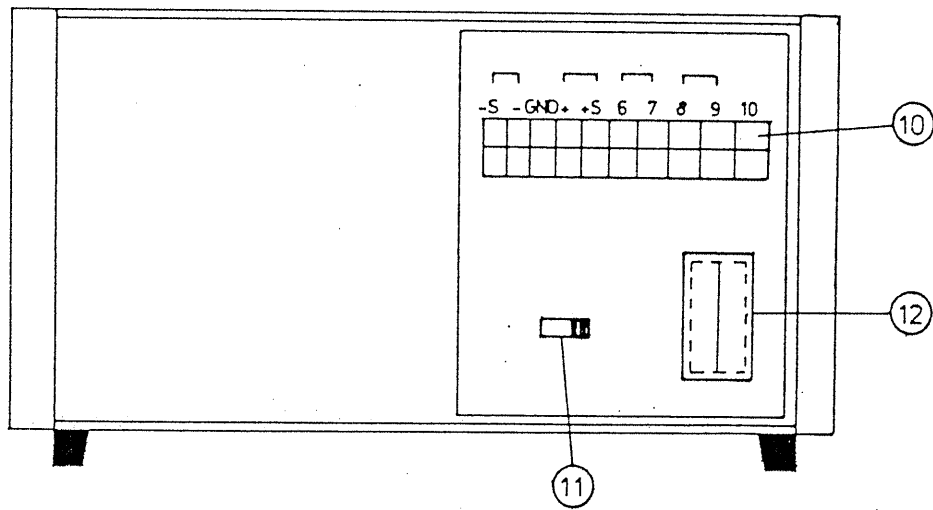

Figure 3-2

3.2 Notes in Use

When using this instrument, pay attention to the following:

(1) Input voltage:

Ensure that the input voltage (AC line voltage) is $100\text{ V} \pm 10\%$,
 48 ~ 62 Hz. (For voltage conversion, contact our representative
 in your area.)

(2) Place of use:

Do not use the instrument in a place as follows:

- o Place where is subjected to direct radiation from a heat source.

783870

- o Place where ambient temperature is not within 0 ~ 40°C.
- o Place where is highly humid or dusty.
- o Place where the surface is not flat.

Never use the instrument being laid down on its side or an object is placed on it. Such will impede heat dissipation and may cause a fatal damage to the instrument.

The two or more units of instruments are stacked or when an instrument is mounted on a rack, allow 50 mm or over of space for each instrument.

(3) Output voltage control knob:

The output voltage control potentiometer is a 10-turn herical potentiometer, with which the output voltage is adjustable very smoothly.

(4) Overshoot:

This instrument is so designed that its output voltage does not become higher than the set voltage, even as transient phenomena when the power is turned on or off.

3.3 How to Use the Sampling Terminals

When the distance from this instrument to the load is long, voltage change at the load end increases due to the voltage drop in the lead wires. Such voltage change can be suppressed by using the sampling terminals. For connections of these terminals, refer to Figure 3-3.

- (1) Remove the jumper wires from between "-S" and "-" terminals and between "+S" and "+" terminals.
- (2) Connect the load to the output terminals of the front or rear panel. Connect the sampling terminals to a point closest to the load or a point where the voltage is to be stabilized.

Note: Make the polarity of the sampling terminals the same with that of the output terminals.

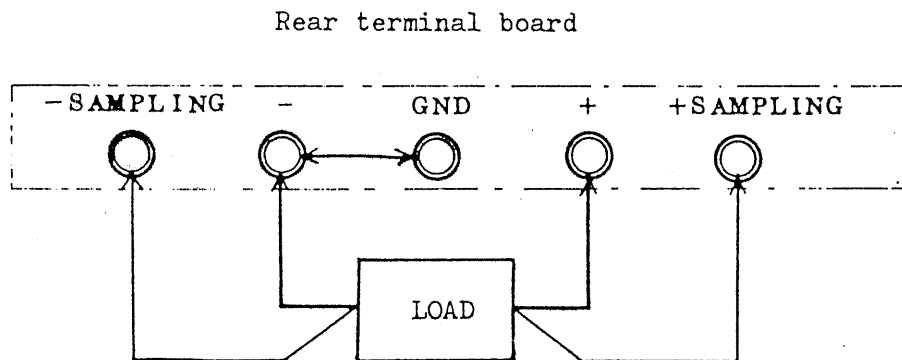

Figure 3-3

Notes: 1. The voltage drop caused by the lead wires is calculated as follows:

$$V_d \text{ (mV)} = I_o \text{ (A)} \times R \text{ (}\Omega\text{)}$$

where, V_d : Lead wire voltage drop (mV)

I_o : Load current (A)

R : Lead wire resistance (Ω)

2. The use of a 2-core shielded cable is recommendable for the sampling lead wires, as such cable protects the sample signal against induction noise and suppresses ripples. Pay attention to the polarity of the sample lead wires.
3. Pay attention to the fact that the set value of constant-current shifts depending on the lead wires resistor to the load.
4. When the sampling lead wires are long, parasitic oscillations are apt to be caused. In order to suppress such oscillations, connect to the sampling point an electrolytic capacitor of several microfarads, working voltage 630 V or over.
5. Note that the sampling operation becomes ineffective when the voltage drop in the lead wires for the connector has become 0.3 V or over.

6. Do not feed the power to the load under the state that the jumper wires are disconnected from between "-S" and "-" terminals and between "+S" and "+" terminals, except when the sampling terminals are used.

3.4 Constant-voltage Constant-current Characteristics

The PAD 600-1 is incorporated with an automatic constant-voltage constant-current transfer feature such that, when the load changes from zero to infinite, the operation change of this instrument is continuous from the constant-current domain range to the constant-voltage domain. The point where the constant-voltage domain crosses with the constant-current domain is called "crossover point." The relationship of these characteristics with respect to the load change is shown in Figure 3-4.

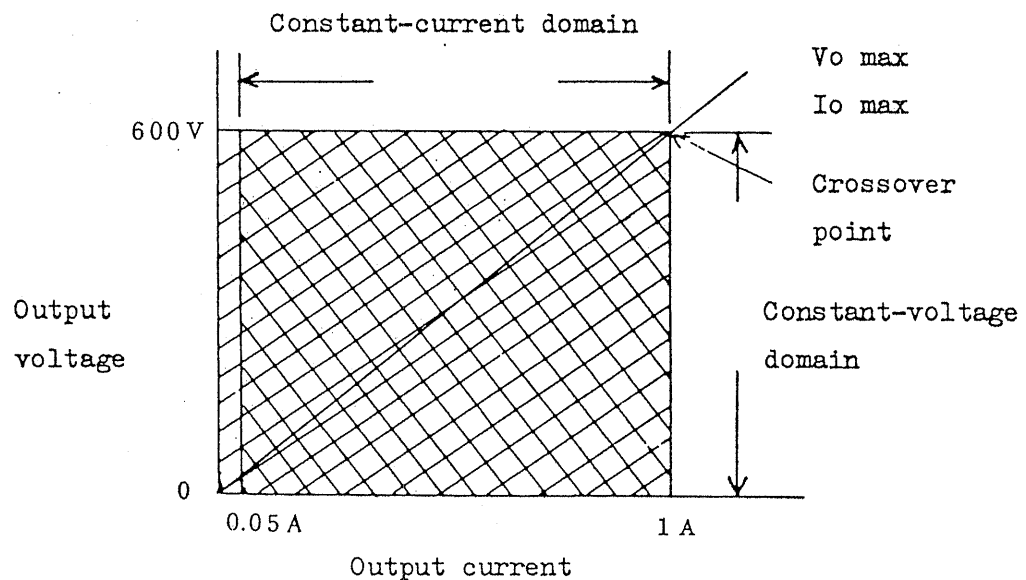

Figure 3-4

78387A

The shaded section of Figure 3-4 indicates the working domain of this instrument. The instrument can operate at any point within this domain.

3.5 Transient Response

This instrument responds with a sufficiently fast speed to transient change of load and it can be used to provide power for such load as digital circuits. This, however, can be said of at the output terminal of this instrument. When the lead wires to the load is long, the inductance of the lead wires becomes not negligible. In such a case, connect a capacitor between the two lead wires at the load side in order to compensate for the lead wire inductance.

Transient response characteristics of this instrument, in terms of the voltage waveform at the output terminal with respect to the load current waveform is shown in Figure 3-5.

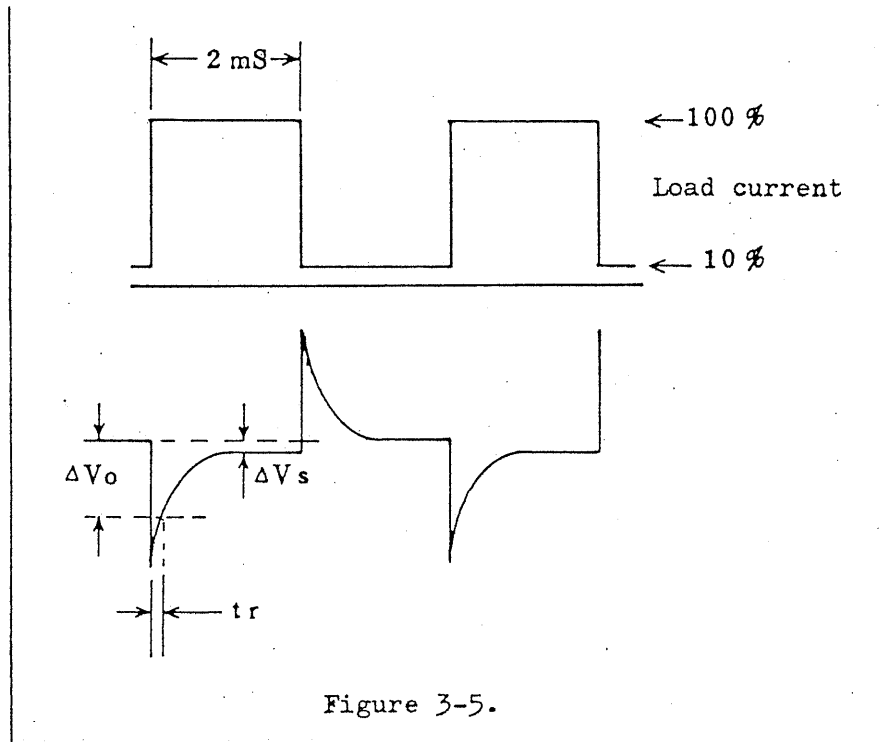

Figure 3-5.

Load current waveform: Duty ratio 50%

ΔV_s : Supply voltage change (steady state) caused by load current change

ΔV_o : 0.1% of output voltage

t_r : Transient response time 50 μ sec (typical)

Examples of transient response waveforms of PAD600-1

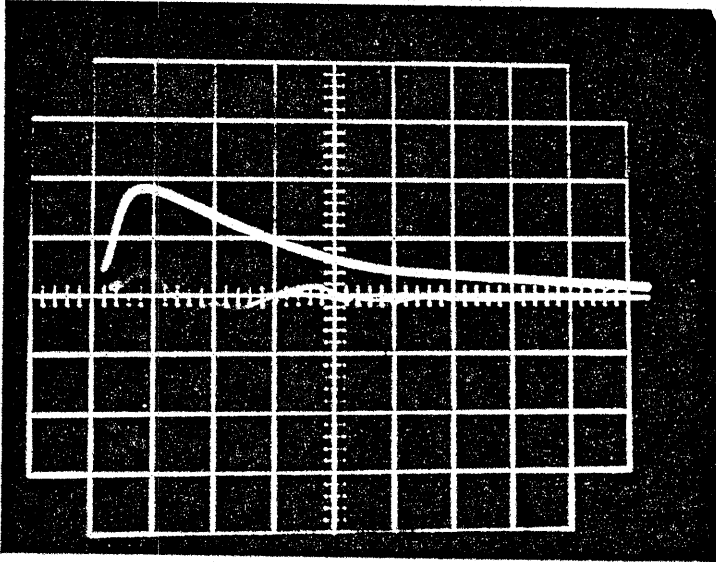

The photo shows a transient response curve of PAD 600-1 at 20°C.

VERT: 0.2 V/DIV

HOR: 10 μ sec/DIV

Output conditions:

200 V, 1 A

Load conditions: 5 ~ 100%

Rise down section:

approx. 30 usec

(See the preceding page.)

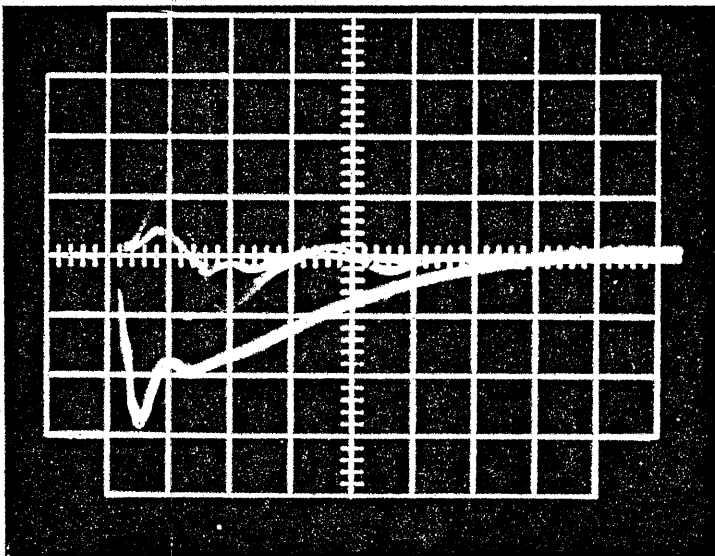

VERT: 0.2 V/DIV

HOR: 10 μ sec/DIV

Rise up section:

approx. 35 μ sec

783877

3.6 Single-unit Operation

Constant-voltage Operation

- (1) Connect the power cord and throw the power switch to the upper position. The instrument will immediately become operating and the power pilot lamp will turn on.
- (2) Turn the CURRENT knob to the fully clockwise position. Under this state, set the VOLTAGE knob at the required voltage.
(The voltage knob increases as this knob is turned clockwise.)
- (3) Connect the load to the output terminals of this instrument.

Note: If the load current is required to be limited at a certain value, short the output terminals of this instrument and set the CURRENT knob at the required value before connecting the load to the output terminals.

Constant-current Operation

- (1) Connect the power cord and throw the power switch to the upper position. The instrument will immediately become operating and the power pilot lamp will turn on.

783878

- (2) Turn clockwise the VOLTAGE knob to the point where the turning becomes slightly heavy (position for the maximum voltage).
- (3) Short the output terminals and set the CURRENT knob at the required value. (The output current increases as the knob is turned clockwise.)
- (4) Connect the load to the output terminals.

- Notes: 1. This instrument is an automatic constant-voltage constant-current transfer type. When the load has increased and reached a certain value, the instrument operation is automatically transferred from the constant-current mode to the constant-voltage mode. Therefore, if it is required to limit at a certain value the voltage applied to the load, set the output voltage by means of the VOLTAGE knob at the required value at the step of procedure of (2) above.
2. The constant-voltage and constant-current modes are indicated by the CV and CC lamps on the front panel.

CV lamp on constant-voltage mode
green LED

CC lamp on Constant-current mode
red LED

783879

3. To use the sampling terminals, refer to Note 3 of the paragraphs for how to use the sampling terminals.

3.7 Parallel Operation

For parallel operation for handling a large load, two or more unit PAD 600-1 can be directly connected in parallel.

- (1) Set the output voltages of the units as close to the operating voltage as possible. (The difference in the set voltages of the units is directly reflected on load change.)
- (2) Turn the CURRENT knobs to the fully clockwise positions.
- (3) Connect together the output terminals of the same polarity, and connect the load to the terminals of the "+" and "-" groups. Of course the grounding polarities of all units must be the same.

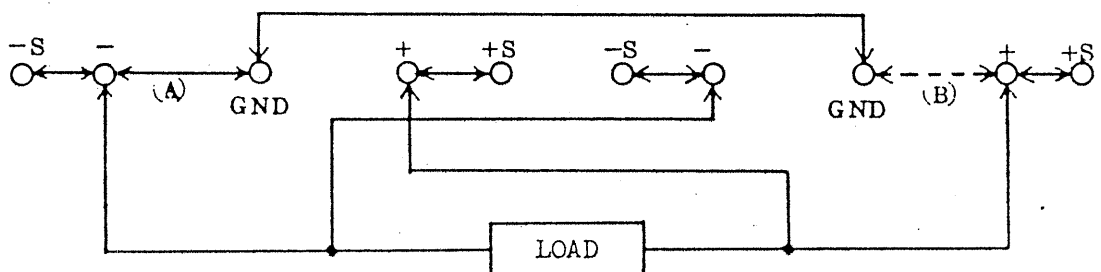

(A) Negative ground

(B) Positive ground

Figure 3-6. Parallel connection diagram

783880

Voltage and current characteristics when in parallel operation:

The voltage and current characteristics when in the parallel operation are as shown in Figure 3-7. The unit (A) of a higher voltage operate until it is overloaded. When this unit is driven into the constant-current domain, its output voltage falls. When the output voltage of this unit has fallen to that of another unit (B), the output voltage of unit B changes from the overvoltage state (caused by unit A) into the normal state. Therefore, the load change causes the output voltage change of ΔV which is the difference of the setting voltages of units A and B, and consequently the ripple characteristics are degraded by the corresponding amount.

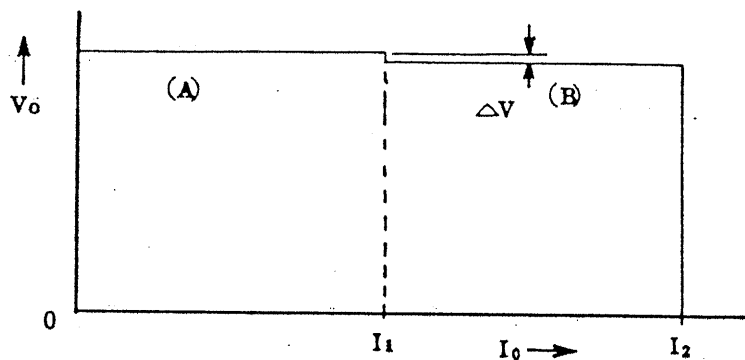

Figure 3-7. Parallel operation characteristics

783881

3.8 One-control Operation (Master/Slave Operation)

The one-control operation (master/slave operation) is employed when a current capacity more than provided with a single unit is required, eliminating the adverse effects which are inevitable when two or more units are operated in the simple parallel operation as in Para. 3.7.

- (1) Connect the rear-panel terminals of the master unit (voltage controlling unit) and slave unit (voltage controlled unit) as shown in Figure 3-8.
- (2) Connect the load to the output terminal of on the rear terminals of the master unit. Turn-ON the power switch and output switch in the due order of master unit and slave unit; turn-OFF the switches in the due order of slave unit and master unit, always.

Notes: 1. If the load is connected to the output terminals on the front panel, the load change characteristics may be slightly degraded and the current balance between master unit and slave unit also may be degraded.

2. To improve the load change characteristics, make use of the sampling terminals. Refer to Figure 3-9 for the connection diagram.

- Keep the VOLTAGE and CURRENT knobs of the slave unit turned to the extremely clockwise position.

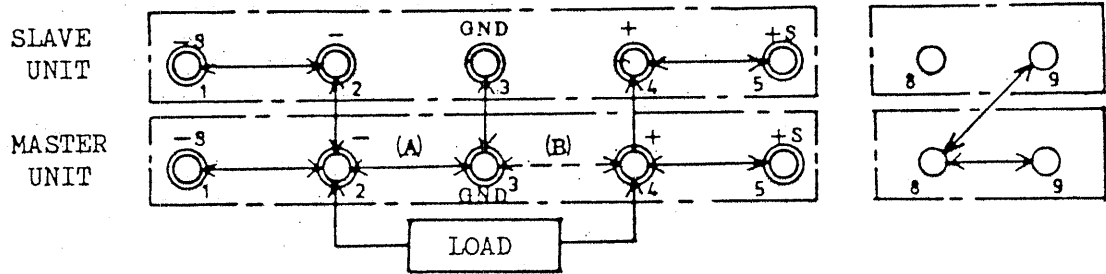

Figure 3-8. One-control parallel operation

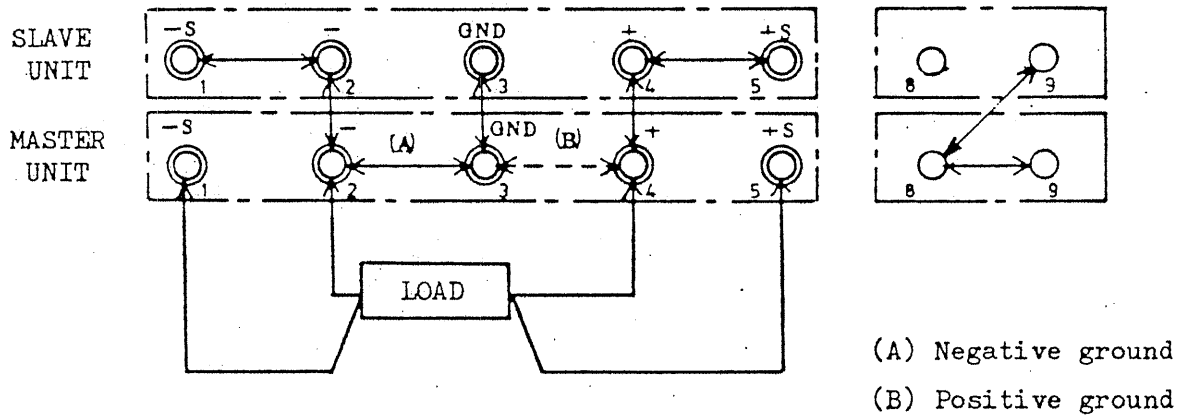

Figure 3-9. One-control operation, with sampling terminals

783883

3.9 Remote Control Operation

Use the REMOTE CONTROL terminal of the rear panel when it is required to control the output voltage from a remote position, to improve the resolution of output voltage change, or to obtain with a switch the preset output voltage.

The PAD 600-1 . employs novel circuits which are substantially different from conventional ones. Before starting the remote control operation, be sure to perform the following:

- (1) Turn-OFF the power switch and then disconnect the jumper wire from between terminals 6 and 7 of the rear terminal.
- (2) Turn the constant-voltage setting potentiometer to the extremely counterclockwise position (zero volt position).
- (3) Connect a variable element between terminals 6 and 10 .

Note: If the line of the variable element becomes open, the output voltage becomes controllable and a high output voltage is produced. Be sure to securely connect the line under the state that the instrument power is turned off.

- (4) When the power switch is turned on, the output voltage is controllable by means of the variable element.

783884

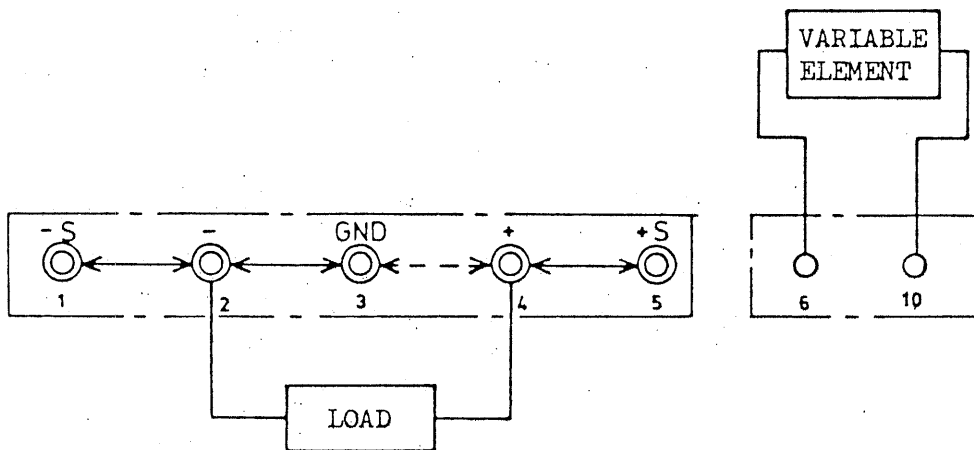

Figure 3-10

3.9-1 To control the output voltage from a remote position:

The output voltage varies at a rate of approximately 30 V/k Ω of the resistor (variable element) connected remotely. The output voltage (V_o) is expressed as follows:

$$\begin{aligned} \text{Output voltage } V_o \text{ [V]} \\ = \text{Voltage change rate (30 V/k}\Omega\text{)} \times R_r \text{ [k}\Omega\text{]} \end{aligned}$$

Where, the voltage change rate is the increment of output voltage per 1 k Ω of resistance change, and R_r denotes the resistance of the remote control resistor.

When no appropriate potentiometer is available and there is a possibility of exceeding the output voltage rating or when the output voltage is required to be limited at a certain value, connect a zener diode (low leak current type) across the potentiometer.

When a zener diode of 60 V maximum is used, the output voltage is limited at approximately 600 V.

Notes: 1. The potentiometer used as the remote variable element must be of a wirewound or metal-film type with a wattage of 0.5 W or over and must be of a small temperature coefficient. Unless attention is paid to these points, the specification temperature coefficient (50 PPM/°C) may not be attained and output voltage drift caused by temperature change may increase.

2. For remote connection, use a 2-core shielded cable or a pair of stranded wires in order that external induction and noise are not introduced and smooth output voltage control can be realized.

3.9-2 To improve the resolution (fine control of output voltage:

The output voltage is proportional to the resistance of the externally-connected remote resistor. Denoting by V_{res} the required voltage resolution, the resistance resolution R_{res} of the external remote resistor to attain this voltage resolution must be as follows:

783886

$$R_{\text{res}} = \frac{V_{\text{res}}}{\text{Voltage change rate } 30\text{V/k}\Omega} \quad [\text{k}\Omega]$$

723287

4. CIRCUIT DESCRIPTION

4.1 Constant-voltage Circuit

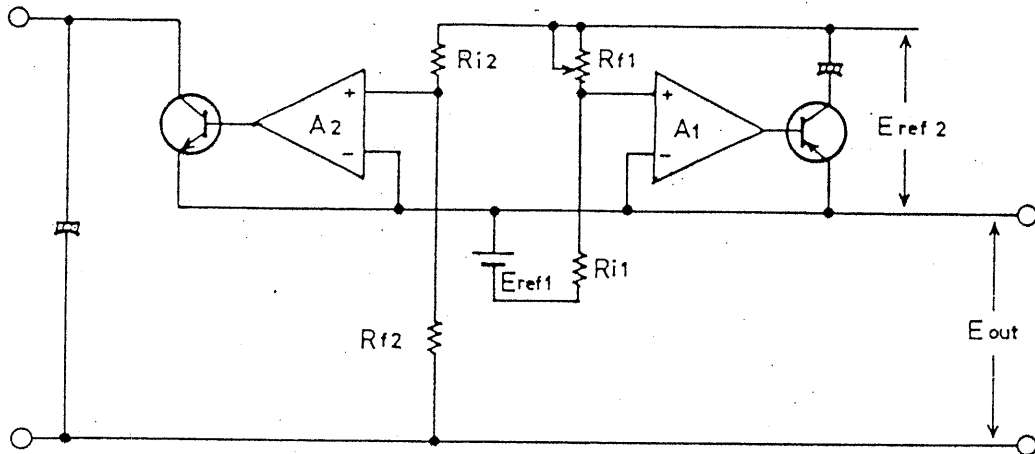

The reference voltage (E_{ref2}) is expressed as follows:

$$E_{ref2} = - \frac{R_{f1}}{R_{i1}} E_{ref1} \dots\dots\dots (1)$$

The output voltage (E_{out}) is expressed as follows:

$$E_{out} = - \frac{R_{f2}}{R_{i2}} E_{ref2} \dots\dots\dots (2)$$

Substituting equation (1) into equation (2), the following equation can be yields:

$$E_{out} = \frac{R_{f1} \times R_{f2}}{R_{i1} \times R_{i2}} E_{ref1}$$

793988

The above equation indicates that the output voltage depends on the reference voltage (E_{refl}) and resistance. Therefore, the resistances of resistors R_{i1} , R_{i2} , R_{f1} , R_{f2} and the voltage of E_{refl} must be sufficient stable against ambient temperature change and other external disturbances. The following types of devices are used to ensure a high stability.

Reference voltage (E_{refl}): Temperature-compensated zener diodes

Input resistors (R_i): Metallic film resistors, 25 PPM/ $^{\circ}$ C,
50 PPM/ $^{\circ}$ C

Feedback resistors (R_f): Woundwire resistor of excellent temperature characteristics with less aging, metallic film resistor of 25 PPM/ $^{\circ}$ C

4.2 Constant-current Circuit

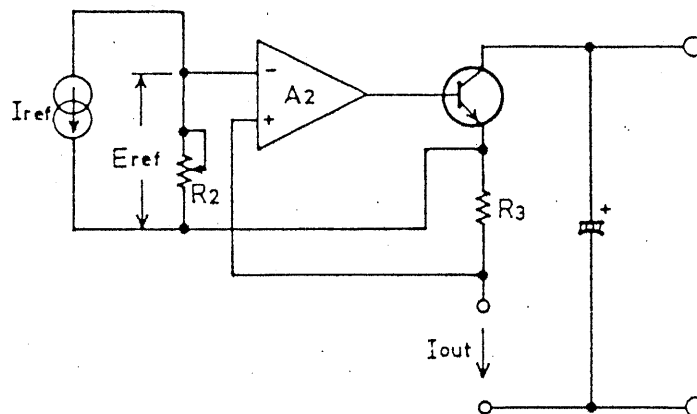

The equation for the constant-current circuit is as follows:

(A2 assumes an ideal amplifier.)

$$I_{\text{out}} = \frac{E_{\text{ref}}}{R_3} = \frac{R_2}{R_3} I_{\text{ref}}$$

783890

783891

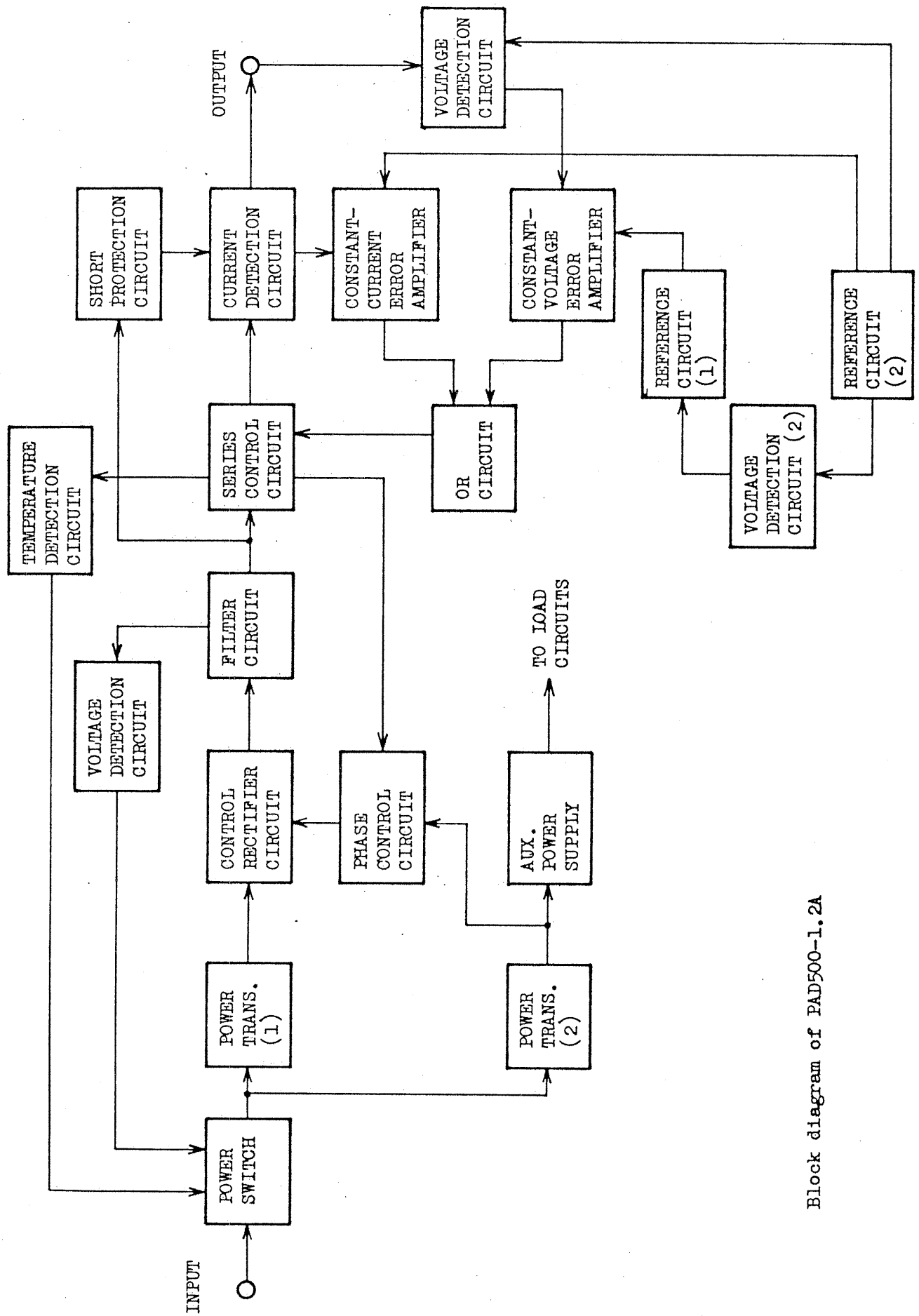

Block diagram of PAD500-1.2A

770124

PAD 600 - 1

INPUT CURRENT - OUTPUT VOLTAGE

INPUT VOLTAGE AC 100V 50Hz

(OUTPUT CURRENT 1A, 0.8A, 0.6A, 0.4A, 0.2A
CURRENT CONST.)

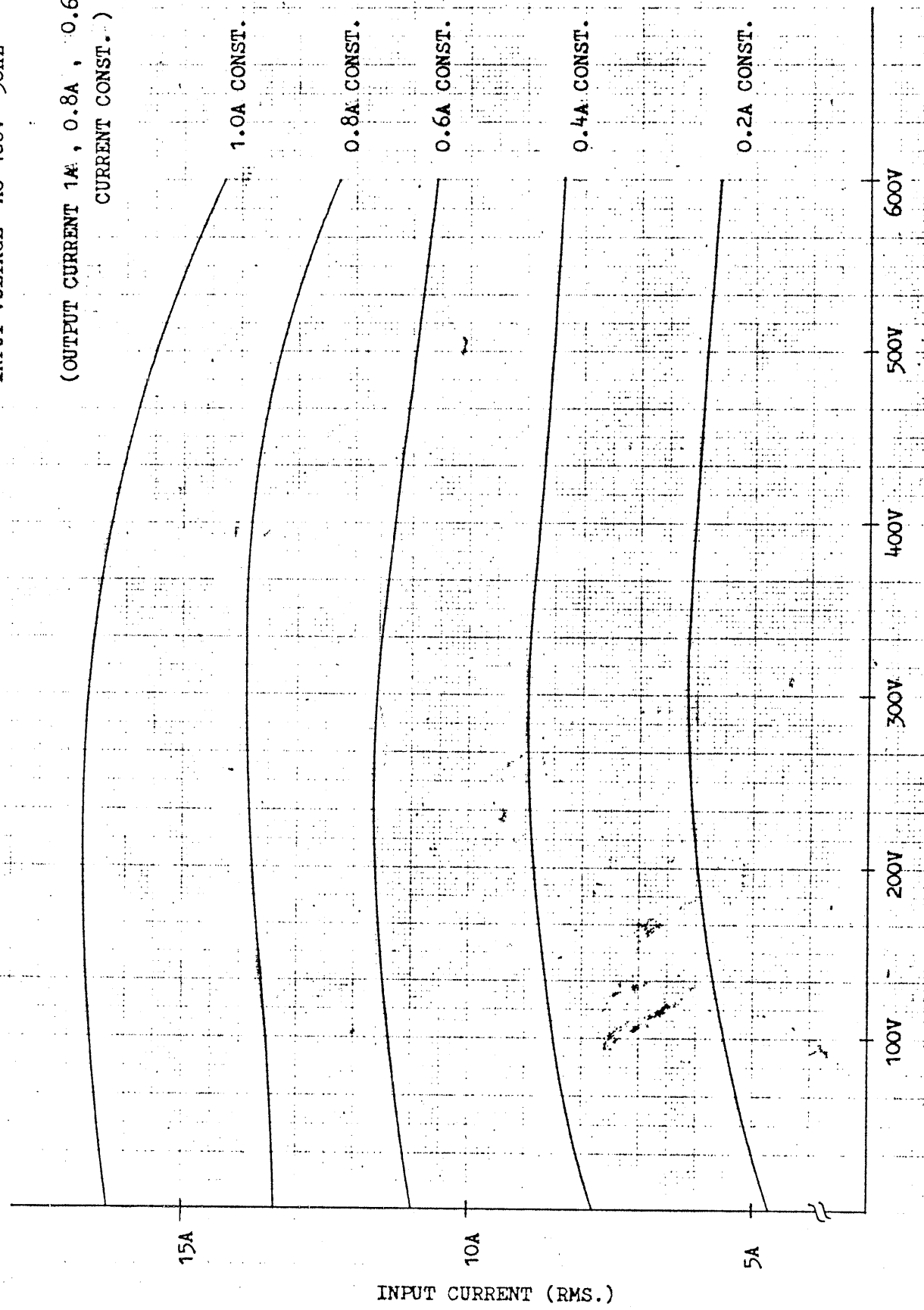

(OUTPUT VOLTAGE) DC---V

INPUT CURRENT (RMS.)